

VIDEO  
ENTRY PANEL

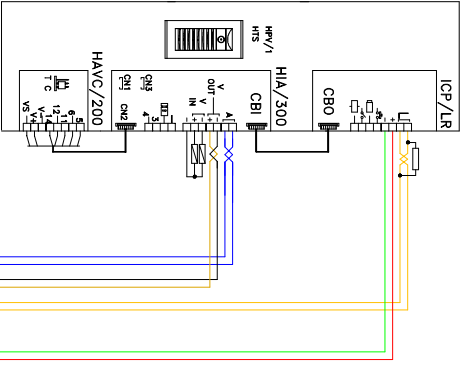

SEE THE HA/200 INSTRUCTIONS FOR  
COLOUR CODE TO HAV/200 TERMINALS

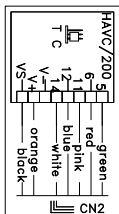
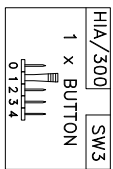
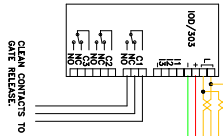

1. IT IS VITAL THAT THE CLOSING RESISTANCES SHOWN ON THE DRAWING AS 588 & 120R ARE CONNECTED AS INDICATED.
2. THE TWISTED PARS MUST NOT BE UNWISTED OR SIMPLY INSERTION INTO THE TERMINALS. THE TWISTED TOGETHER ALL THE WAY INTO THE TERMINALS

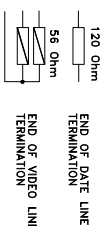

IN THIS CONFIGURATION SHOWN

PLEASE NOTE THE MAXIMUM DISTANCE BETWEEN ENTRY PANEL AND XA/300 CANNOT EXCEED (150M USING 4 PAIR CATS + 2 CORES @ 1.0MMSQ)

PLEASE NOTE THE MAXIMUM DISTANCE BETWEEN XA/300 AND FURTHEST MONITOR CANNOT EXCEED (100M USING 4 PAIR CATS + 2 CORES @ 1.0MMSQ).

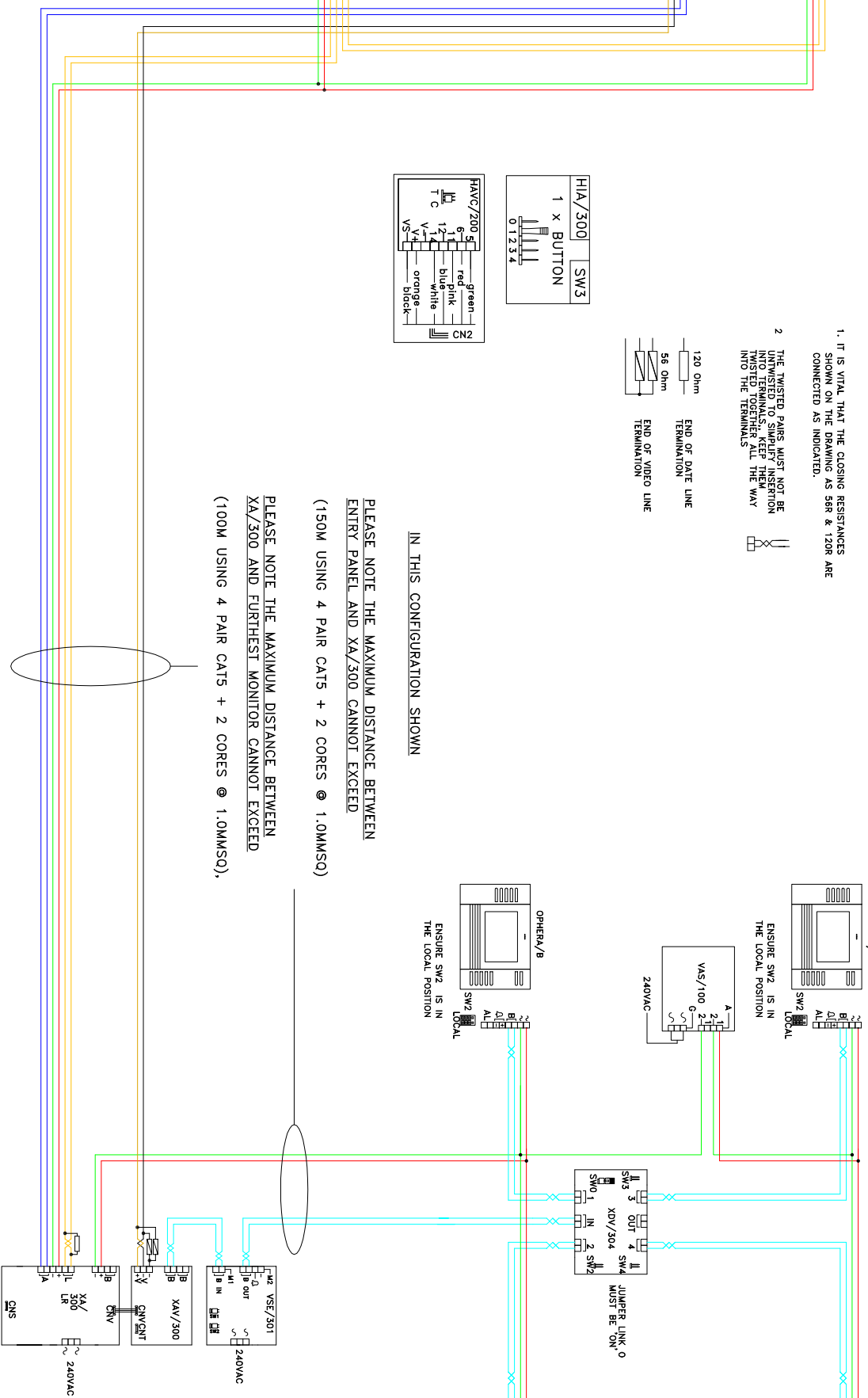

BPT (UK) LTD. HERTS, ENGLAND	PREPARED FOR	DATE: 04/10/07	DRAWN/R/C
	INSTALLER INFORMATION	REVISED:	
DRAWING TITLE: 1 X 1 BUTTION TARGRA VIDEO ENTRY PANEL & 4 OPHERA MONITORS WITH INTERNAL INTERCOM		DRAWING No: C-111P4CI	